



Accurate Valve Positioning

The Posi-flate® 5000 Series Pneumatic Positioner provides accurate valve positioning with advanced features. It may be used with 3-15 PSI pneumatic control signals (as shown), or fitted with one of three current-to-pressure transducers for 4-20 mA signal inputs. The pneumatic positioner is available with many options including limit switches, position feedback transmitter and a visual dome indicator.

Applications

A high spool valve, plus an adjustable gain system, make the pneumatic positioner well suited for use with all pneumatic rotary actuator types including rack-and-pinion, heavy duty and others.

The positioner housing is constructed from durable die-cast aluminum and treated with a dichromate undercoat and polyester powder top coat for protection against the toughest applications in all process industries.

Features

- *Non-interactive span adjustment.* Reduces calibration time.
- *Adjustable gain.* Allows positioner sensitivity adjustment without removing or replacing components.
- *Corrosion-resistant materials.* All exposed parts are constructed of heavy-duty anodized aluminum.
- *Captive cover screws.* Permits calibration without potential for losing screws.
- *Optional visual dome indicator.* Provides fully adjustable, high-contrast, full-angle viewing of valve position.
- *Field upgradable* - to any of three electro-pneumatic options without removing the cover. Switches or a position transmitter can be installed in the field by replacing the shaft and adding modular cards.
- *Vibration resistant.* Low spool mass, outboard spool bearings and locking calibration adjustments provide reliable operation under high vibration.

Principles of Operation

The Posi-flate model 5000 positioner causes rotation of a valve actuator in proportion to an input signal. This signal is in the form of pneumatic pressure. Supply pressure is directed to the actuator through a precision spool valve. As input pressure is varied, the balance beam moves away from its neutral position.

The spool also shifts and a differential pressure is created across the actuator, causing rotation. Rotation is fed back through the positioner shaft and cam. Cam rotation causes rotation of both follower arm and feedback arm about their respective pivot pins. Rotation of feedback arm changes compression in the feedback spring which forces the balance beam and spool back to their neutral positions. This shuts off the flow of air to the actuator.

Zero adjustment is made by varying spring compression via a screw in the feedback arm. Span adjustment is made by moving the point of contact between the follower arm and feedback arm via a carriage assembly featuring rack-and-pinion adjustment. Since both arms are parallel at zero, span adjustment does not affect zero setting.

Gain adjustment is made by varying hinge spring stiffness via an adjustment assembly. This assembly slides along and clamps the hinge spring, thereby changing the spring stiffness.

Posi-flate models 5100, 5200 and 5400 include an I/P module which converts an electrical 4-20 mA current signal into the pneumatic signal required to operate the positioner.

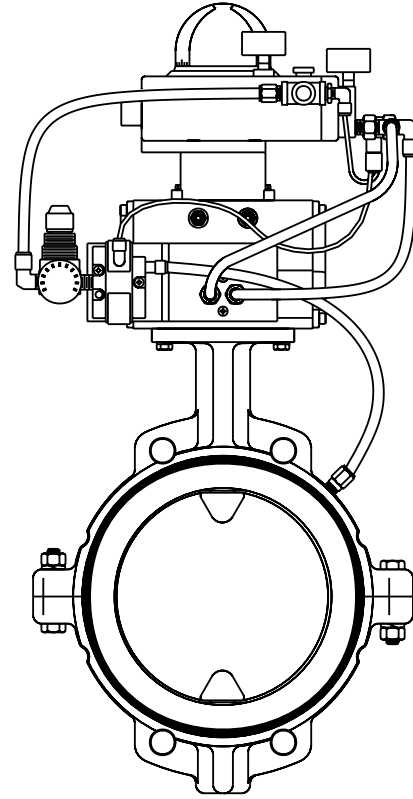

Posi-flate Butterfly Valve With Model 5100 Positioner

When used on a Posi-flate butterfly valve as shown above, the positioner is enhanced with the addition of controls which automatically inflate and deflate the seat. Once the disc is in the fully closed position, the seat is automatically inflated. When the positioner is energized to open, the seat deflates and the disc opens.

Dimensions

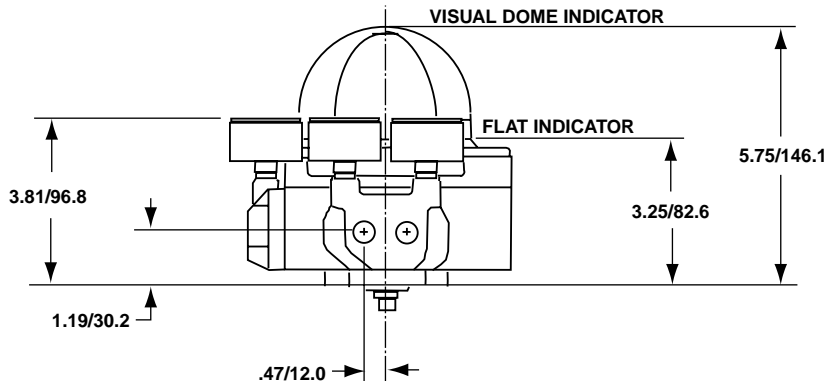

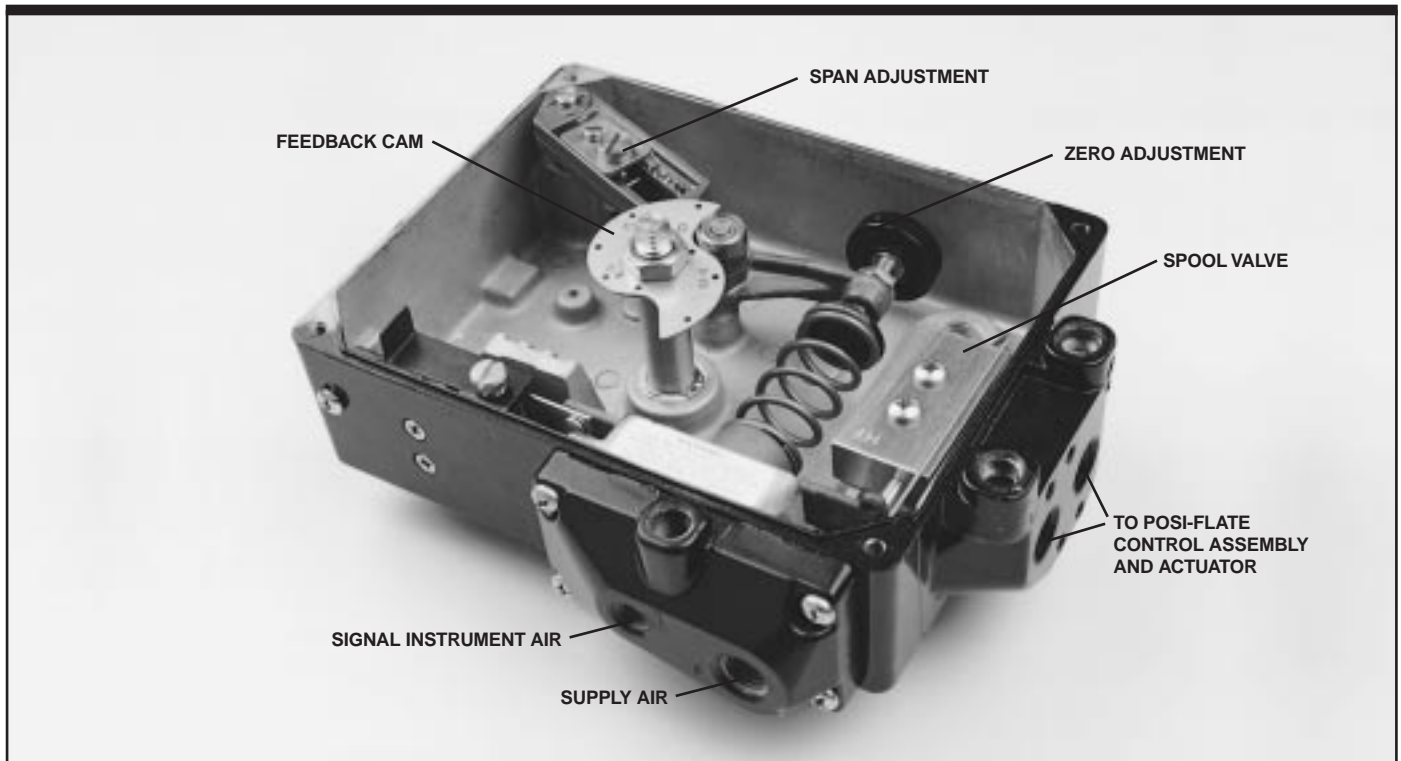

Materials of Construction

Part	Materials
Housing/Cover	Aluminum w/Dichromate/Powdercoat
Shaft	Stainless Steel
Cam	Stainless Steel
Cam Follower Bearing	Hardened Steel
Follower/Feedback Arms	Hard Anodized Aluminum
Span Adj. Slide/Lockscrew	Stainless Steel
Span Adj. Pinion	Plated Steel
Zero Adj. Screw	Stainless Steel/Phenolic
Pivot Pins/Snap Rings	Stainless Steel
Feedback Spring	Stainless Steel
Balance Beam	Hard Anodized Aluminum
Hinge Spring	Plated Steel
Spool Valve	Stainless Steel
Gain Adj. Assembly	Plated Steel
Diaphragm	Nitrile Rubber
Diaphragm Cover	Hard Anodized Aluminum
Manifold	Aluminum w/Dichromate/Powdercoat
All Fasteners	Stainless Steel
All O-ring Seals & Gaskets	Nitrile Rubber

Performance Specifications

Parameter	Units & Value
Resolution	0.5% Full Scale
Deadband	0.5% Full Scale
Repeatability	0.5% Full Scale
Hysteresis	0.5% Full Scale
Linearity	1% Full Scale
Gain - High Flow	30% - 110%
Supply Pressure Effect	0.05%/1 PSIG
Supply Pressure Range	30 - 120 PSIG
Air Consumption	0.3 SCFM
Ambient Temp. Range	-40 to 18 *Degrees F
Temperature Effect	0.5%/1 Deg. F
Input Signal	3 - 15 PSIG

* Specify viton seals for 180 to 300 degree applications

Posi-flate 5000 Series Ordering Information

Code	Description
------	-------------

Base Model - Input Signal Option

Heavy-Duty Aluminum Construction

A50	Posi-flate 5000 - 3-15 PSI Pneumatic
A51	Posi-flate 5100 - 4-20 mA - NEMA 4 Design
A52	Posi-flate 5200 - 4-20 mA - NEMA 7 FM and CSA Approved
A54	Posi-flate 5400 - 4-20 mA - Intrinsically Safe FM and CSA Approved

Visual Indicator

1	Flat Indicator
2	Visual Dome Indicator

Gauges

4	Standard Gauges
5	Stainless Steel Gauges

Spool Valve

7	High Flow Spool Valve
---	-----------------------

Code	Description
------	-------------

Cam

A	Standard Linear Cam
---	---------------------

Options (add in alphabetical order)

F	4-20 mA Position Feedback Transmitter
K	(2) SPDT Mechanical Switches
M	(2) SPDT Proximity Switches
N	(2) SPST Proximity Switches
P	Viton Seals
R	Epoxy Coated
T	NAMUR Shaft

Part No.	Description
----------	-------------

Controls - Posi-flate Seat Inflation Controls*

1057899	Auto Inflate/Deflate Controls
---------	-------------------------------

* Required when positioner is used with Posi-flate butterfly valve assembly.

How To Order

Choose one option from each category above including Base Model - Input Signal Option, Visual Indicator, Gauges, Spool Valve and Cam. These are the minimum codes required to specify a complete positioner figure number. Add options as necessary. Please list them in alphabetical order.

Posi-flate seat inflation controls are required when the positioner is used with a Posi-flate butterfly valve assembly.

Examples

A50-1-4-7-A w/PN 1057899

Basic Posi-flate model 5000 positioner with 3-15 PSI pneumatic input, flat indicator, standard gauges, high flow spool valve, linear cam and auto inflate/deflate controls.

A51-2-5-7-A-F-T w/PN 1057899

Posi-flate model 5100 positioner with NEMA 4, 4-20 mA electro-pneumatic input, visual dome indicator, stainless steel gauges, high flow spool valve, linear cam, 4-20 mA position feedback, NAMUR shaft and auto inflate/deflate controls.

Posi-flate® is a registered trademark of Posi-flate, St. Paul, MN.

posi-flate[®]
butterfly valves

1125 Willow Lake Blvd., St. Paul, MN 55110-5193 • (651) 484-5800 • Fax: (651) 484-7015

Printed in U.S.A. - Bulletin 9805